

EXTRA NG 60" RXR

Receiver-Ready Aircraft by
EXTREME FLIGHT

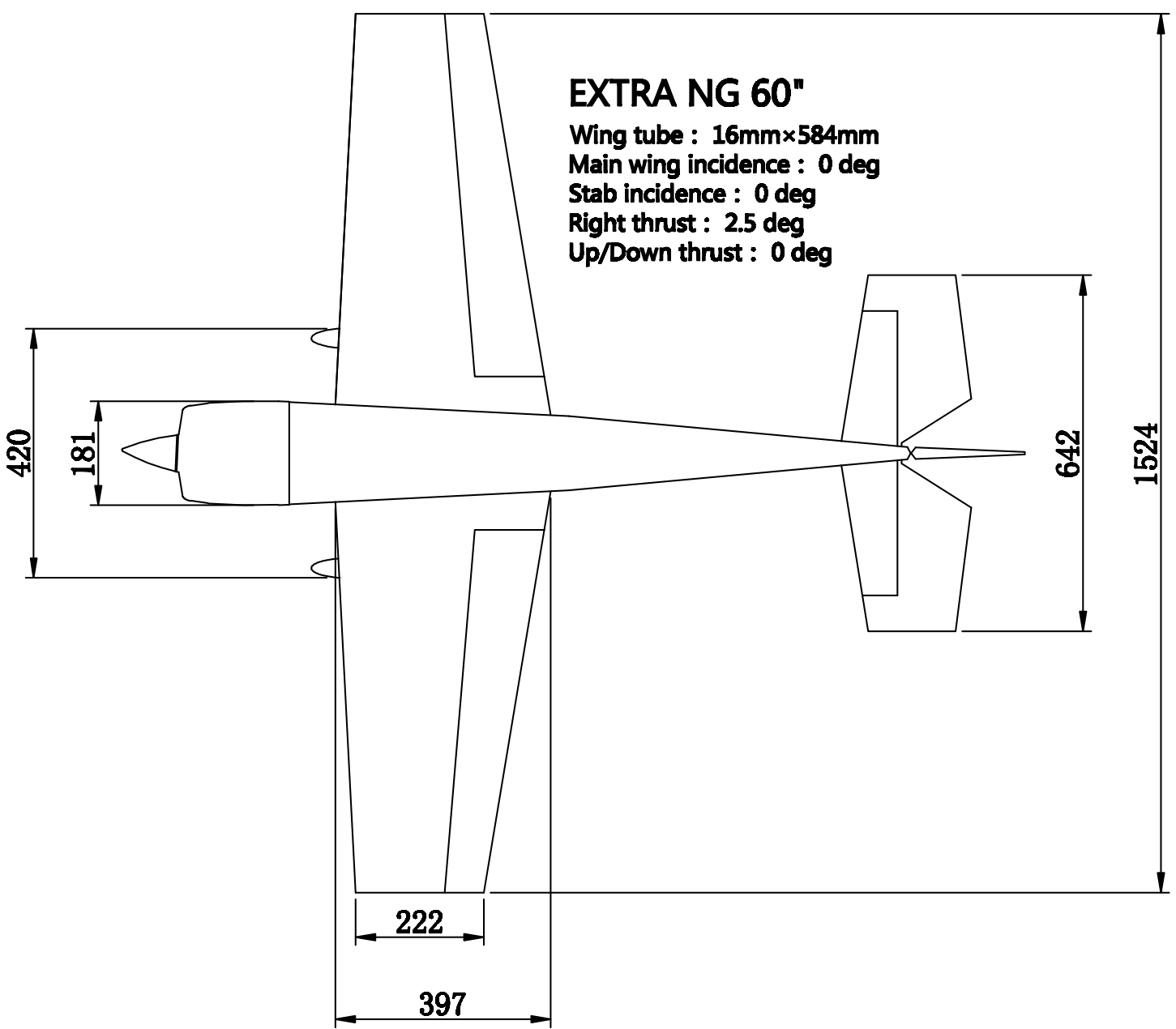
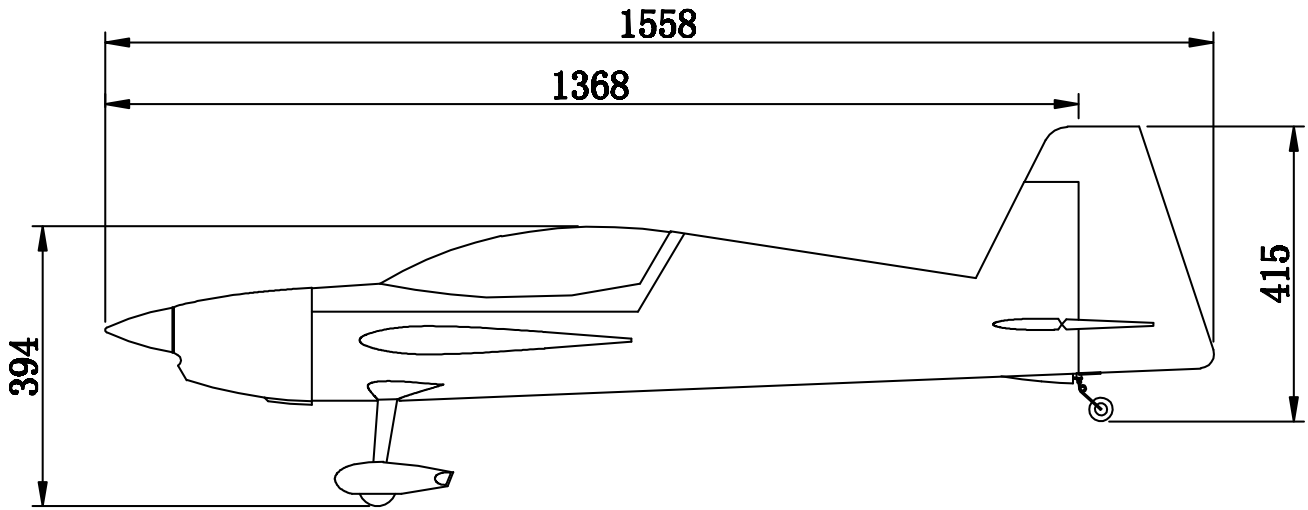

SPECS

WingSpan: 60" Spinner: 63mm
 Length: 61" Weight: 6-6.5 lb
 Wing area: 731 sq. in.

REQUIRES 6S 3300-4000mah lipo

Center of Gravity: Balance on the wing tube for precision flight or easy sport flying.
 Back of the wing tube to 1/2" behind the tube for 3D flight.

Control settings:

Elevator: Low Rate 8-10 deg. 15-20% expo
 3D Rate 45-50 deg. 60-65% expo
 XA/Tumbling rate 60+ deg. 65-70% expo

Aileron: Low Rate 15-20 deg. 40-45% expo
 High Rate 38-40 deg. 70-75% expo

Rudder: Low Rate 20 deg 40-45% expo
 High Rate 45-50 deg. 80-90% expo

Power system:

T-Motor AM600 Motor INSTALLED
 T-Motor AM116A ESC INSTALLED
 T-Motor 16x8 prop INSTALLED

Servos:

QTY 4 EF/Theta 988 INSTALLED

QTY 4 Extreme Flight 1.25" Servo arms INSTALLED

COVERING:

Blue/White Scheme

Oracover colors	Ultracote colors	RAL Paint Code
Pearl Charcoal #77	Pearl Charcoal #HANU846	N/A
Pearl Blue #57	Pearl Blue #HANU845	N/A
Dark Blue #52	Midnight Blue #HANU885	RAL5013
Cub Yellow #30	Cub Yellow #HANU884	RAL1003
Silver #91	Silver #HANU881	N/A
White #10	White #HANU870	RAL9010

Red/Silver Scheme

Oracover colors	Ultracote colors	RAL Paint Code
Pearl Charcoal #77	Pearl Charcoal #HANU846	N/A
Silver #91	Silver #HANU881	N/A
White #10	White #HANU870	RAL9010
Black #71	Black #HANU874	N/A
Ferrari Red #23	True Red #HANU 866	RAL3000

EXTREME FLIGHT X