

EDGE 540 67"

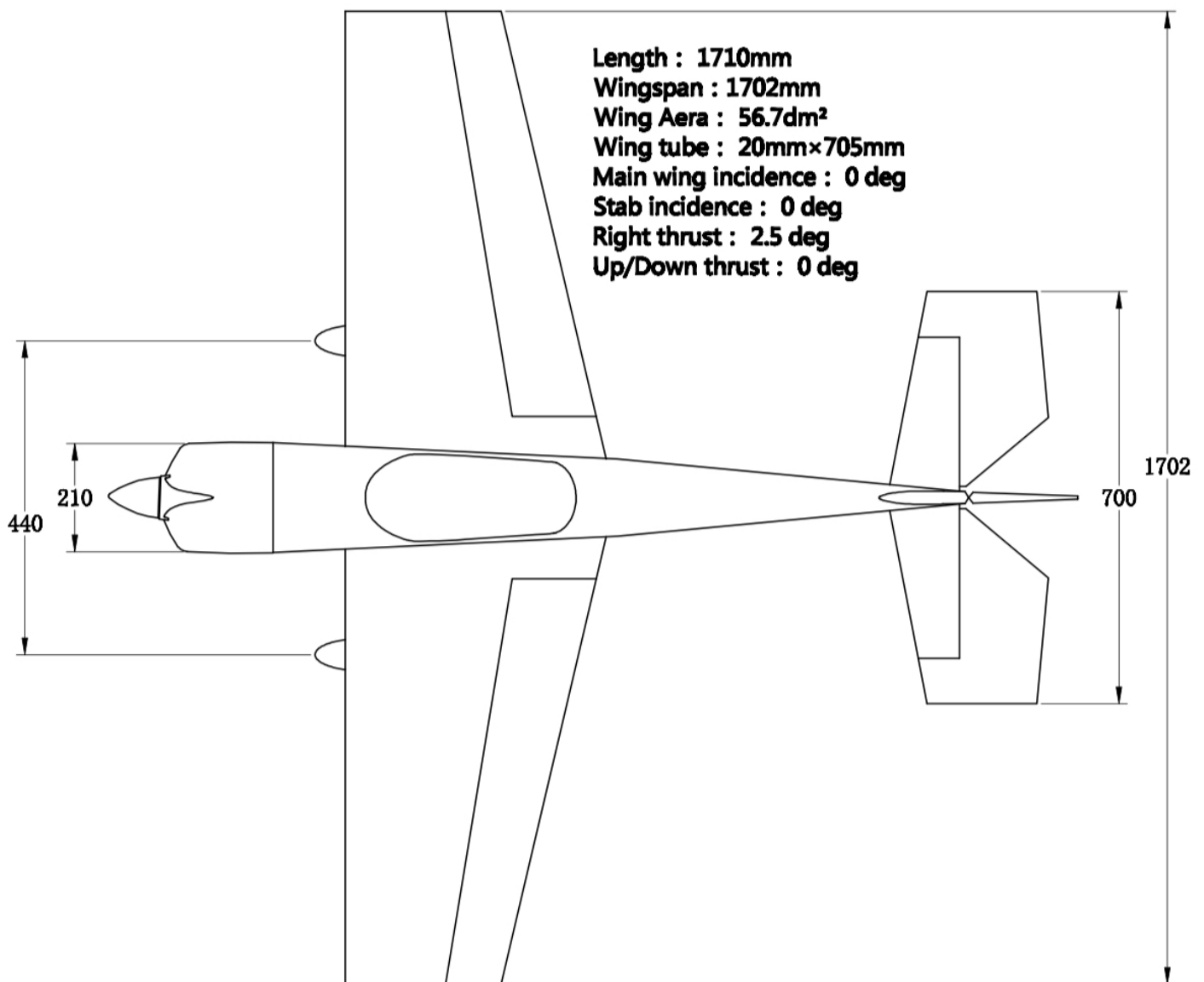
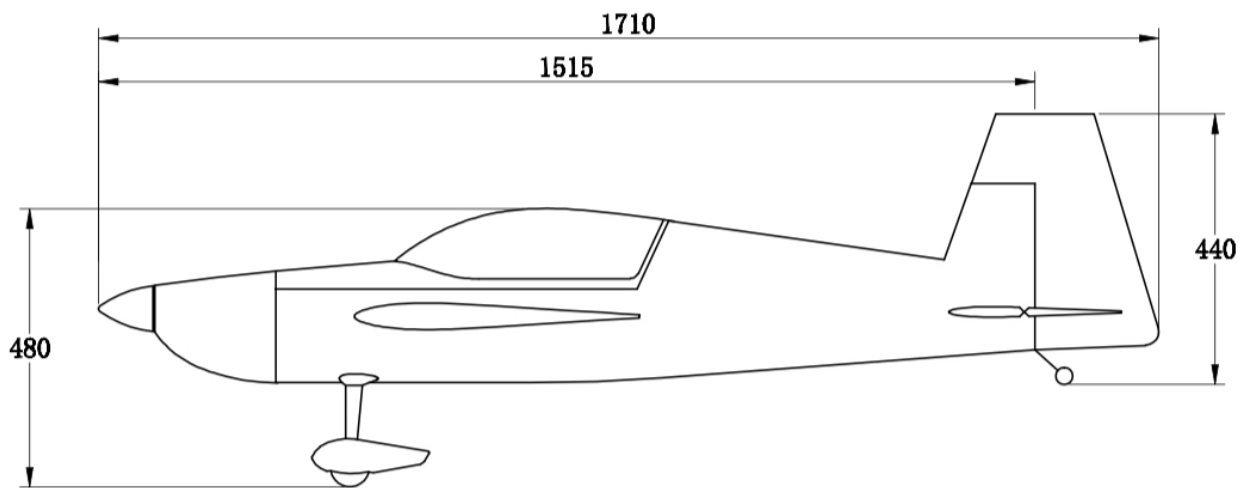

SPECS

WingSpan: 67"
Length: 67"
Wing area: 879 sq. in.

Spinner: 76mm included
Weight: 8 lbs.

Center of Gravity Range: Balance on the wing tube for a nose-heavy CG for extra precision and easiest landings. For 3D and XA, hang by the fuselage former immediately behind the wing tube, airplane should hang level. Tune to your preference.

Control settings:

Elevator: Low Rate 8-10 deg. 15-20% expo
3D Rate 45-50 deg. 60-65% expo
XA/Tumbling rate 60+ deg. 65-70% expo

Aileron: Low Rate 15-20 deg. 40-45% expo
High Rate 38-40 deg. 70-75% expo

Rudder: Low Rate 20 deg 40-45% expo
High Rate 45-50 deg. 80-90% expo

Power system:

Motor: Tmotor AM 670
ESC: Tmotor AM116A
Battery: 6S 4000-5000mah
Prop: Tmotor 18x8

Servos:

Qty. 4 Mini metal-gear digital EF/THETA989, SAVOX 1261 (NOTE: use only the very strongest mini servos available)
QTY 4 Extreme Flight 1.25" Lightweight servo arms

Servo Extensions:

Qty. 2 Extreme Flight 28 AWG 6 inch for Rx to Ailerons
Qty. 2 Extreme Flight 28 AWG 12 inch for Ailerons
Qty. 2 Extreme Flight 28 AWG 24 inch for Elevators and rudder

COVERING:

Oracover colors

BLUE SCHEME
Cub Yellow #30
Cadmium Yellow #33
Blue #50
White #10
Dark Blue #52
Silver #91

RED SCHEME
Ferrari Red #23
Red #20
White #10
Pearl Charcoal #77
Silver #91
Black #71

Ultracote colors

Cub Yellow-#HANU884
Bright Yellow-#HANU872,
Deep Blue-#HANU873
White #HANU870
Midnight Blue #HANU885
Silver #HANU881

True Red #HANU 866
Deep Red #HANU 871
White #HANU870
Pearl Charcoal-#HANU846
Silver #HANU881
Black #HANU 874

EXTREME FLIGHT X